

(此線徑為UL1430 AWG22)

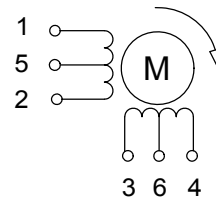
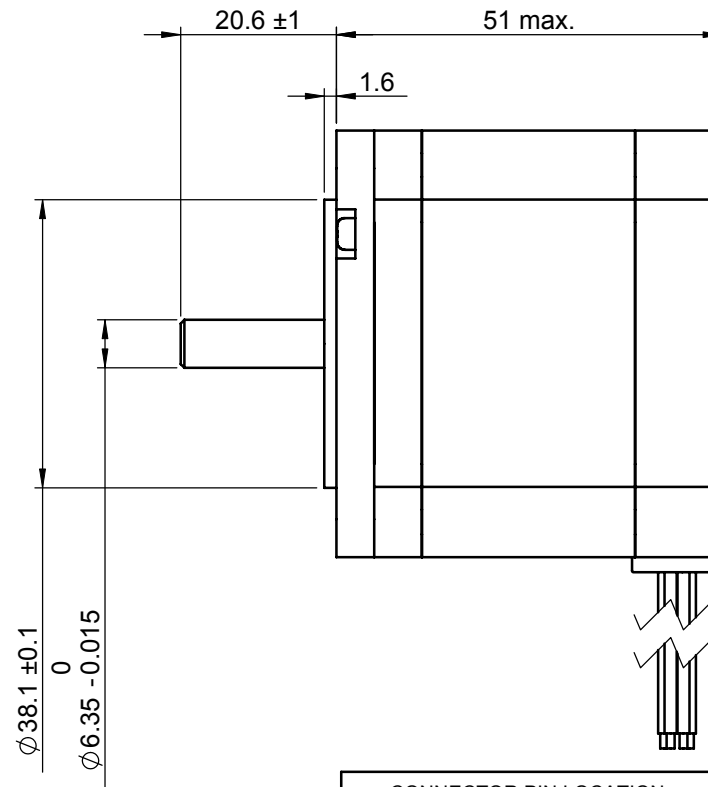

CONNECTOR PIN LOCATION					
PIN	COLOR	CCW ← → CW			
1	BLACK	+	-	-	+
2	GREEN	-	+	+	-
3	RED	+	+	-	-
4	BLUE	-	-	+	+
5	YELLOW				
6	WHITE				

註：以雙極性驅動板測試

 THIRD ANGLE PROJECTION ALL DIMENSION ARE IN MM (UNLESS OTHERWISE SPECIFIED)	製圖	JOANNE	Cheshire Electric Company, LLC		
	設計		Part No JH57-F0G1A771		
繪製比例: 1:1	審核		Name HB stepper motor	REV. NO.	B
	材料				
	完成時間	2012/9/14			

MODEL		Motor Characteristics					
JH57-F0G1A771		Resistance	Step Angle	Steps Revolution	Max PIT Rate	Max POT Rate	POT(at300pps)
Constant current	24V 0.5 A	6.6Ω	1.8 °	200	700PPS	800PPS	7740g-cm